

avatech solutions
building design
facilities management
infrastructure design
product lifecycle management
mechanical design

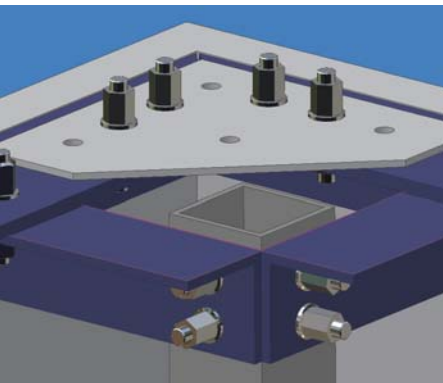

“Avatech’s custom request-for-quote solution allowed us to increase the number of proposals we send out without increasing staff time. Not only has Avatech saved us hundreds of man-hours, but their solution also helps us to be more responsive to our clients in this extremely time-sensitive market.”

—Trey Nemeth,
Vice President, Operations
www.stealthsite.com



STEALTH® CONCEALMENT SOLUTIONS

Online quote system integrated with design automation improves time to market.

THE ORGANIZATION

An industry leader in wireless antenna concealment systems, STEALTH® Concealment Solutions, Inc, designs, engineers, and manufactures custom enclosures for antennas. Based in North Charleston, South Carolina, the company has worked with all of the largest wireless service providers throughout the United States, as well as completing projects in Europe, Australia, and South America. With the growth in popularity of cell phone and other wireless communications devices, the need for communications providers to populate landscapes with antennas to broadcast signals has mushroomed. Unclad cell towers are unsightly and building owners often reject requests for prime placement on building tops without an attractive concealment structure. STEALTH® Concealment Solutions systems help wireless companies obtain zoning and building owner approvals without degrading antenna performance. The company has successfully installed rooftops, flagpoles, light poles, bell and clock towers, signs, water towers, silos, crosses, chimneys, louvers, trees, and side-mounted boxes to conceal antennas.

THE CHALLENGE

While some concealment solutions have similar components, for example flagpoles or rooftop cladding, every one of them needs to be altered slightly to accommodate the site or other external constraints. In some cases, a church steeple for example, the structure is completely customized.

To answer customer requests for quotation, the company’s 20-member, distributed sales force was using a combination of phone calls, emails and faxes to communicate information to the home office for proposal processing. Information sometimes would get lost in the translation from the initial requirements input from sales to design, through estimating and back to sales again.

Trey Nemeth, Vice President of Operations at STEALTH® Concealment Solutions, knew that they could increase business if they responded to customer requests more quickly and accurately at the beginning of a job. He also knew that they could turn their products around faster if their design engineers automated some aspects of their Autodesk® Inventor™ design work once a job was awarded, especially with their product lines that are mass-produced and refined for each site.

“I had worked with Avatech before, when they helped us successfully move from Autodesk® Mechanical Desktop to Autodesk Inventor and we were very happy with the results of that move, so I went back to them to find a creative solution to my quotation, proposal, and design challenges,” said Nemet.

THE SOLUTION

From Quote...

Avatech created an online quotation entry system that sales people could use with just a web browser and Internet connection. The system moves the sales person through a series of questions based on the product category they select from among eighteen product lines. If, for example, a sales person is producing request-for-quotation submittal for a rooftop structure, the system asks them about dimensions, any materials requirements (i.e.; brick, stucco, corrugated, etc.), whether or not the structure will require ballast, or if it will be fixed to the roof. These are not the same questions the system would ask if the structure was for a flagpole, silo, or sign. Each product line requires different standard inputs, and the sales person is walked through that process. Based on a particular answer, the system can ask "follow-up questions" based on the answer to the previous question. By following this decision tree, the sales person is assured they are asking and answering the right questions to inform the engineering process.

Photos can also be uploaded to the web site to aid in the estimation process. The field sales force can now produce complete request-for-quote documents quickly and ensure all the necessary information is captured for proper assessment leading to a more accurate estimation.

The quotation entry system is linked to a database used to generate proposals based on the product category. This sets up a template proposal for the project to make life easier for the in-house estimating team. The system selects the template that most closely resembles the job, based on inputs. The estimator then can make adjustments as necessary and sends the completed proposal back to the sales person.

... To Delivery

Avatech developed tools to automate the creation of complex 3D concealment assemblies and drawings for the company's most popular product lines. "For rooftop installations and flagpoles, we generated a set of rules which creates the 3D model very rapidly, using our knowledge of best practices in engineering and materials properties," said Nemeth. This solution allows designers and engineers to quickly work from

the details gathered in the quotation process, which pre-populate an Autodesk Inventor assembly with parts, dimensions, texture, and other information. Together Avatech developers and STEALTH® engineers generated a list of best practices and engineering rules and constraints for each product line. Avatech automated these best practices and engineering rules in Autodesk Inventor so that engineers can focus on high-level design, rather than on the mechanics of the drawing technology.

SIGNIFICANT REWARDS

Faster Customer Response

"Avatech's custom request-for-quote solution allowed us to increase the number of proposals we send without increasing staff time. Not only has Avatech saved us hundreds of man-hours, but the solution also helps us to be more responsive to our clients in this extremely time-sensitive market," said Nemeth.

More Accurate Quotations

Because estimators don't have to re-input information from one system to another, quotations are based on more accurate information. The system also ensures that information is complete by ensuring all critical fields are completed, so sales staff can't forget to relay important product requirement details. "It's a lot easier for our quotations to be more accurate today, based on our knowledge of designs in the past and the cost to manufacture them, given product variables," said Nemeth.

Improved Time to Design

It now takes less time to generate a new design due to the automation application that Avatech developed. "I estimate that for applicable standard rooftop structures, the automations that Avatech created save as much as 50% in drafting time. So whereas it used to take an engineer a day to model a concealment, today it might take only a couple of hours," said Nemeth. "We've been growing rapidly and to keep up with demand both in sales and design, we rely on the advantages that advanced technologies provide us. Getting antennas on-air quickly is what all wireless carriers want. We can meet their needs better and faster than competitors due to our use of the technology solutions Avatech created for us."

THE FUTURE

“Because flagpoles are popular and often more standardized products, we’re working on automating some aspects of their design to further improve efficiency, reusing existing design work. As the boom in wireless communications continues we will continue to grow,” said Nemeth. “We are the founders of the wireless concealment industry, and Avatech’s innovations will help us to keep up with our ever-increasing volume of work for a long time to come.”

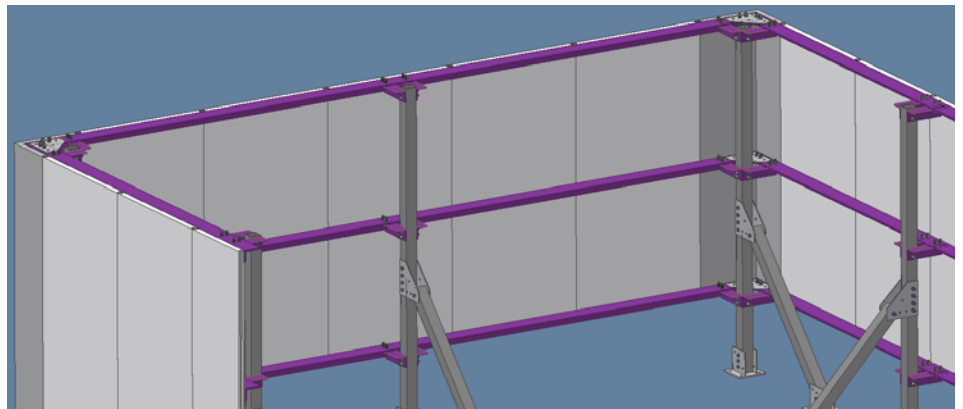

Can you spot the Cell Antennas in the pictures above?

ABOUT AVATECH

Avatech Solutions is a leading engineering systems integrator, with unique solutions that enable companies to more effectively design, develop, and manage projects, products, and facilities.

We get results with the unique capabilities of our team of industry-experienced professionals—application engineers, consultants and strategists, trainers, software developers, and project managers.

With offices nationwide, we specialize in process optimization, software implementation and integration, standards development and deployment, education, and technical support.

Our expertise is real. And so are the results that we bring to our clients. Avatech can help you succeed, with solutions that align your technology and processes to your organization’s goals—for results the way you define them.

To learn more call 1.800.706.1000 // visit www.avatech.com

All trademarks, brands, and names are the property of their respective owners.



AVATECH
SOLUTIONS®

Altogether Smarter Design.

Corporate Office
10715 Red Run Blvd, Ste 101
Owings Mills, MD 21117
Phone: 800-706-1000
Fax: 410-581-8088
Web: avatech.com

Autodesk
Authorized Training Center